

TABLE OF CONTENTS	
PAGE	DESCRIPTION
M-00	3D VIEW
M-01	ANCHOR BOLT & PLAN VIEWS
M-02	ELEVATIONS
M-03	ELEVATIONS
M-04	ELEVATIONS
M-05	BILL OF MATERIAL

REV.	DATE	BY	DESCRIPTION
1	07/13/18	JS	ISSUED FOR APPROVAL

Project :		
Project No. :		
Status : Not Set	Comment:	
Detailer :	Holes:	Client:
DraftingServices.com	Weld: E70XXELECT	Drawing No.
Checker:	Grade:	M-00
	Coating:	Phase:
	Date: 07-13-2018	

SEAL	ENGINEER
------	----------

Quantity Description Length

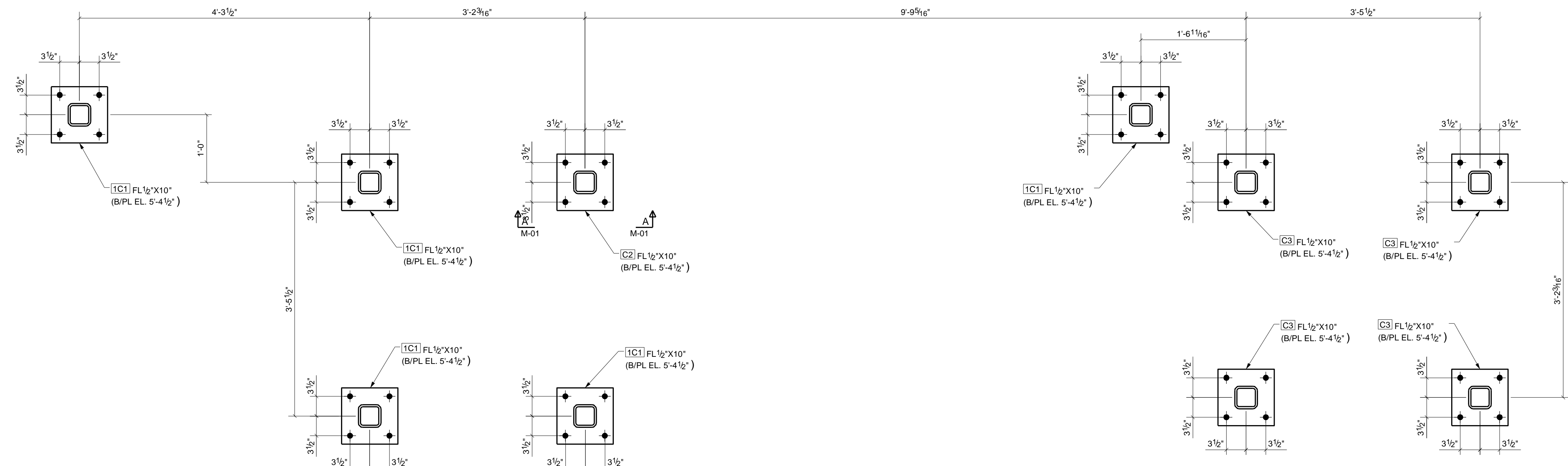

ANCHOR BOLT PLAN @ FRONT STAIR
SCALE: 1" = 1'-0"

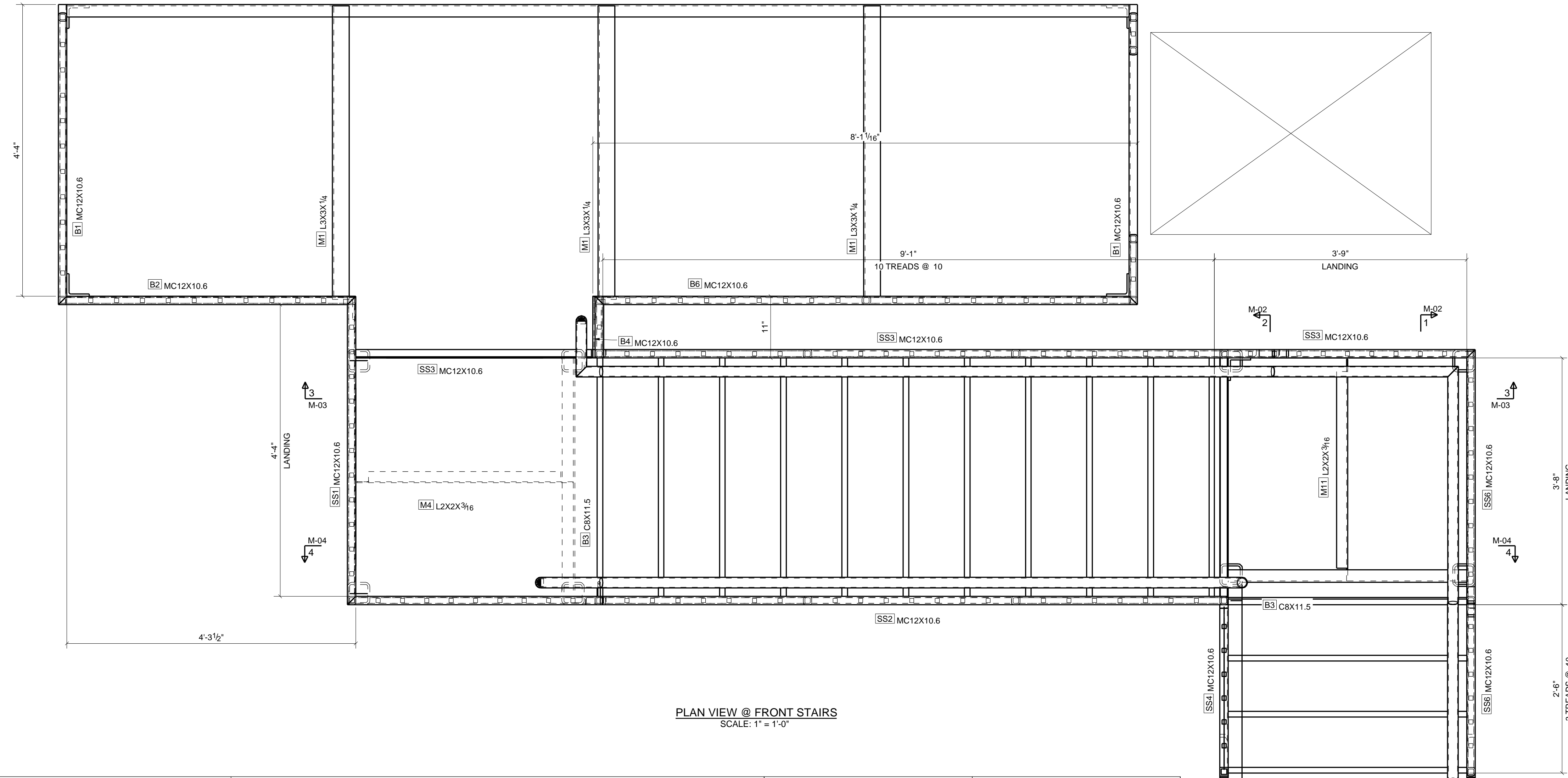
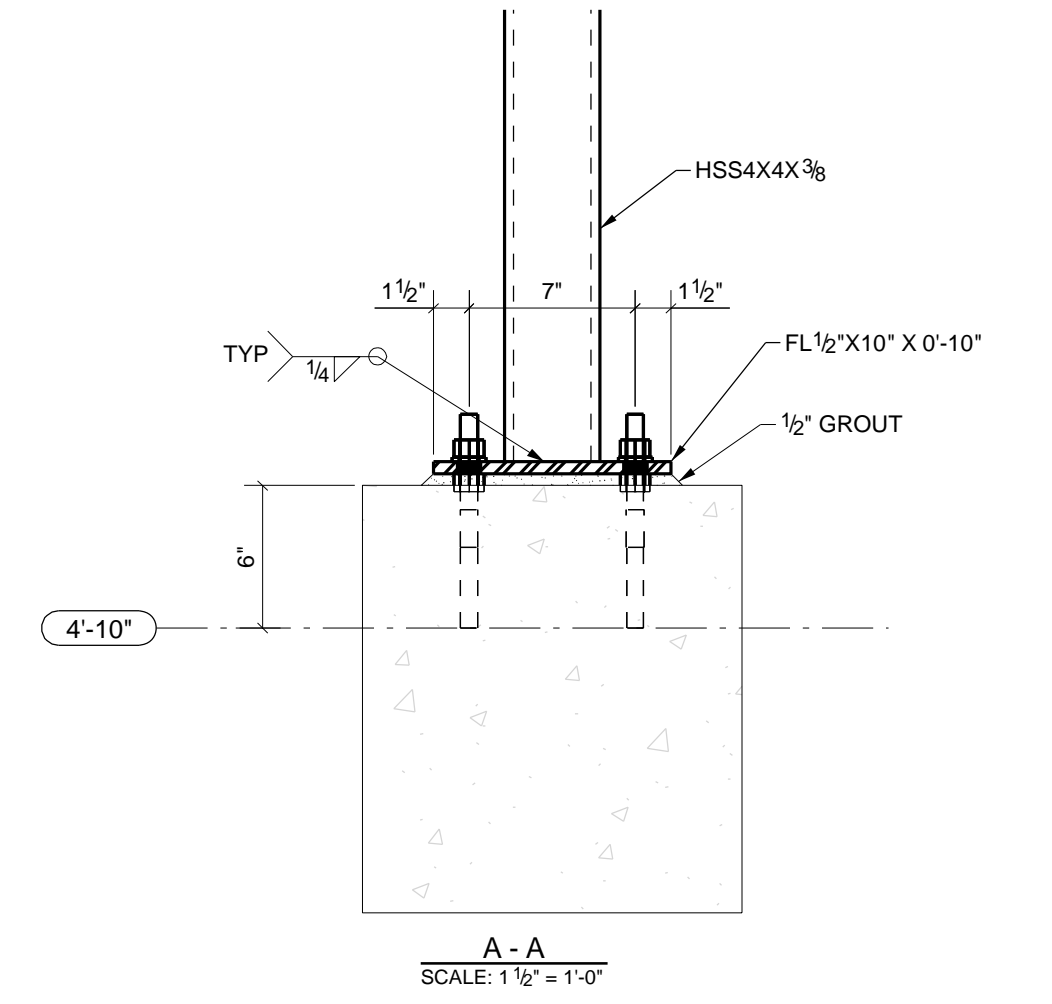

PLAN VIEW @ FRONT STAIRS
SCALE: 1" = 1'-0"

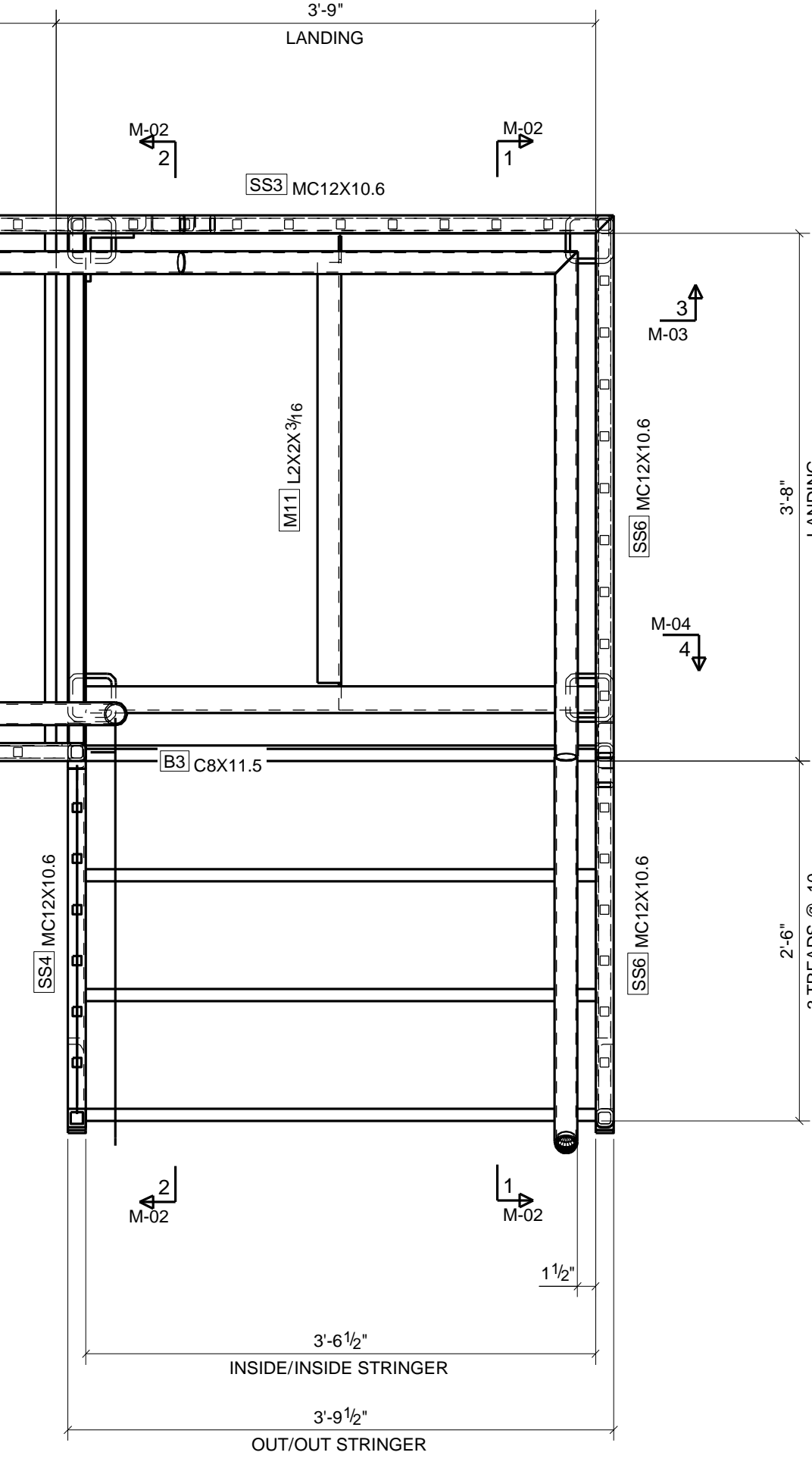

Quantity Description Length

SEAL ENGINEER

REV.	DATE	BY	DESCRIPTION
1	07/13/18	JS	ISSUED FOR APPROVAL
Project :			
Project No. :			
Status : Not Set	Comment:		
Detailer :	Holes:	Client:	
DraftingServices.com	Weld: E70XXELECT	Drawing No. M-01	
Checker:	Grade:	Phase:	
	Coating:	Date: 07-13-2018	
		A	

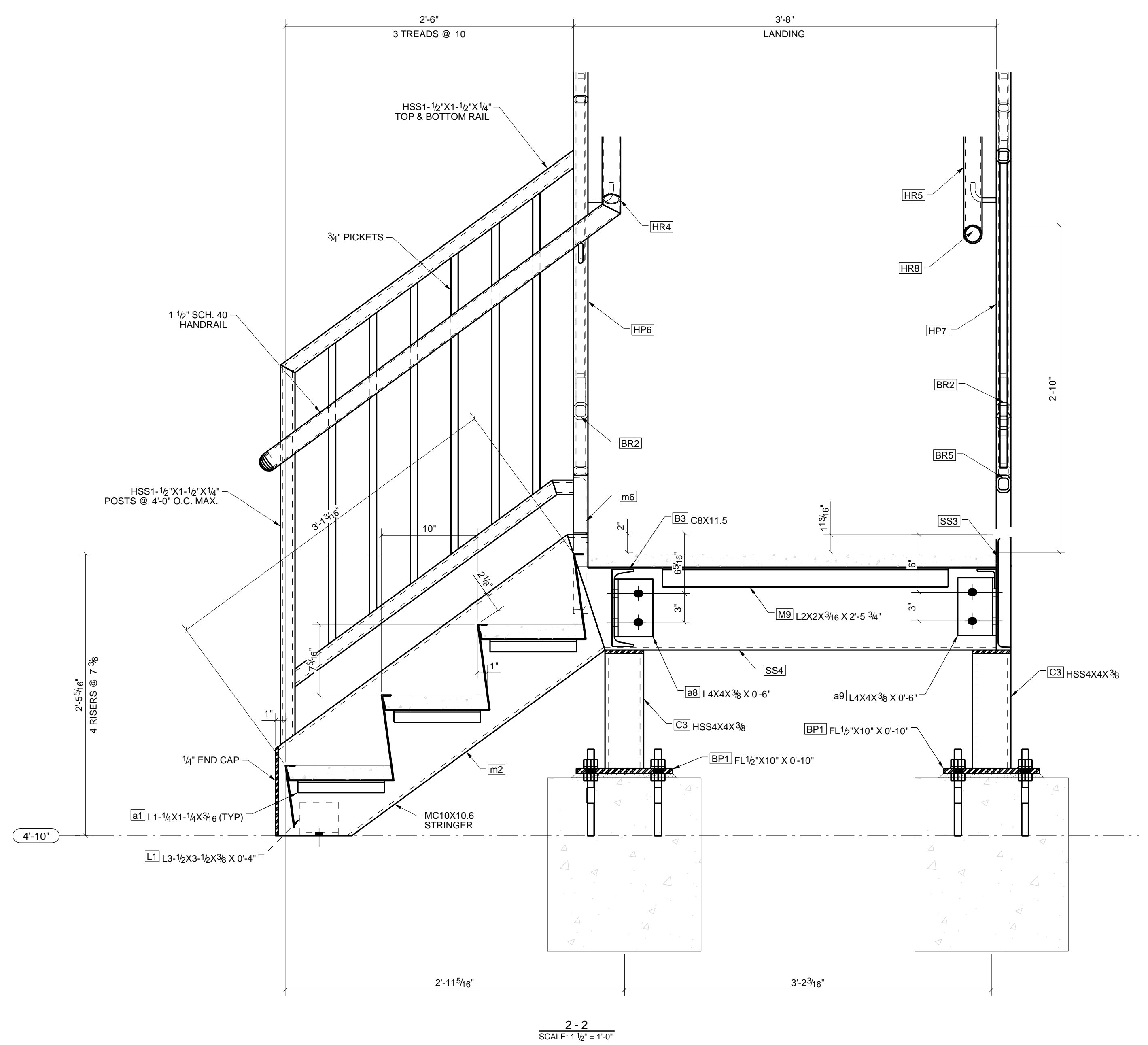
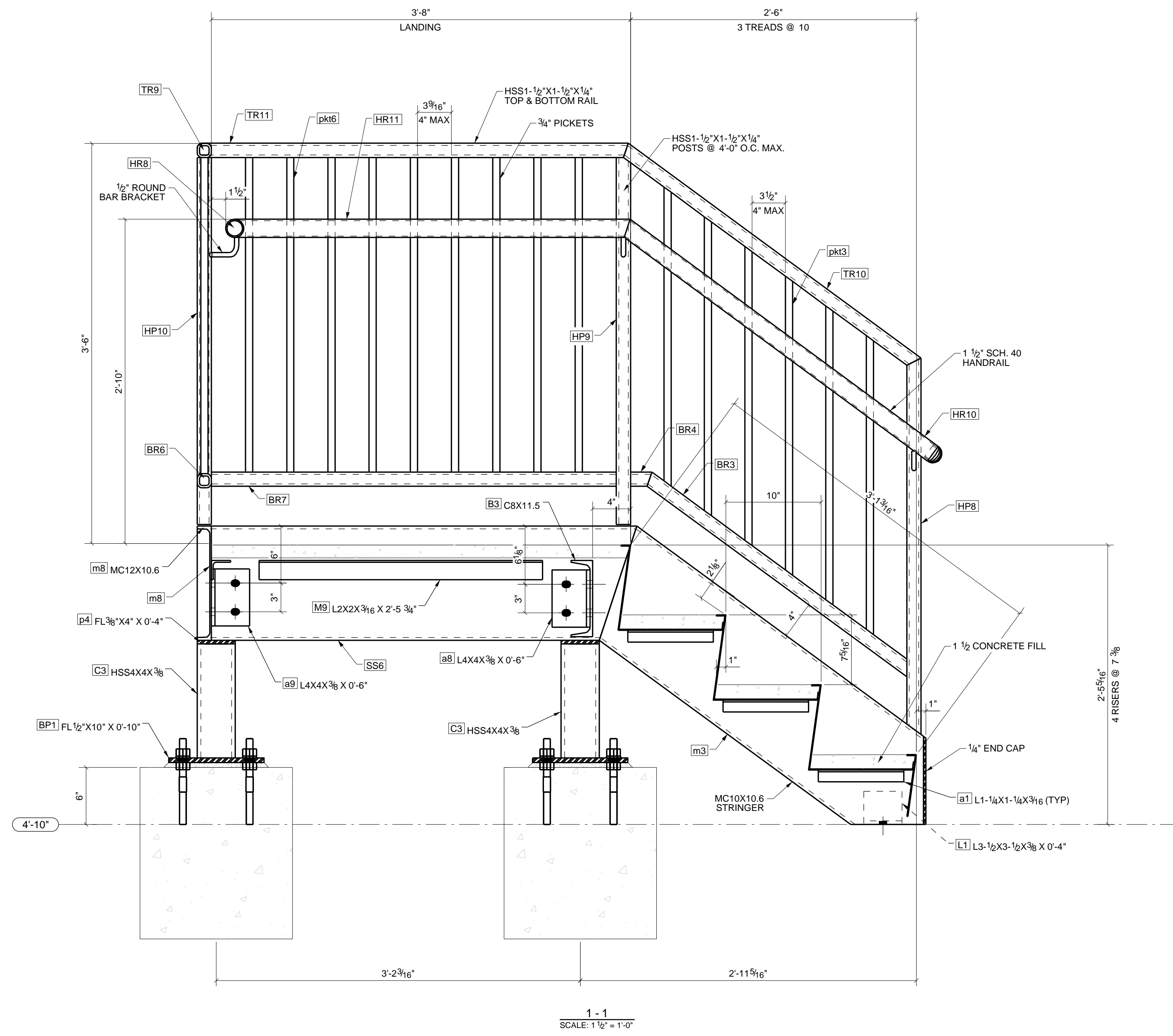

REV.	DATE	BY	DESCRIPTION
1	07/13/18	JS	ISSUED FOR APPROVAL

Project :	
Project No. :	
Status : Not Set	Comment:
Detailer : DraftingServices.com	Holes:
Checker:	Weld: E70XXELECT
	Grade:
	Coating:
	Date: 07-13-2018

Client:	Drawing No. M-02
Phase:	A

SEAL

ENGINEER

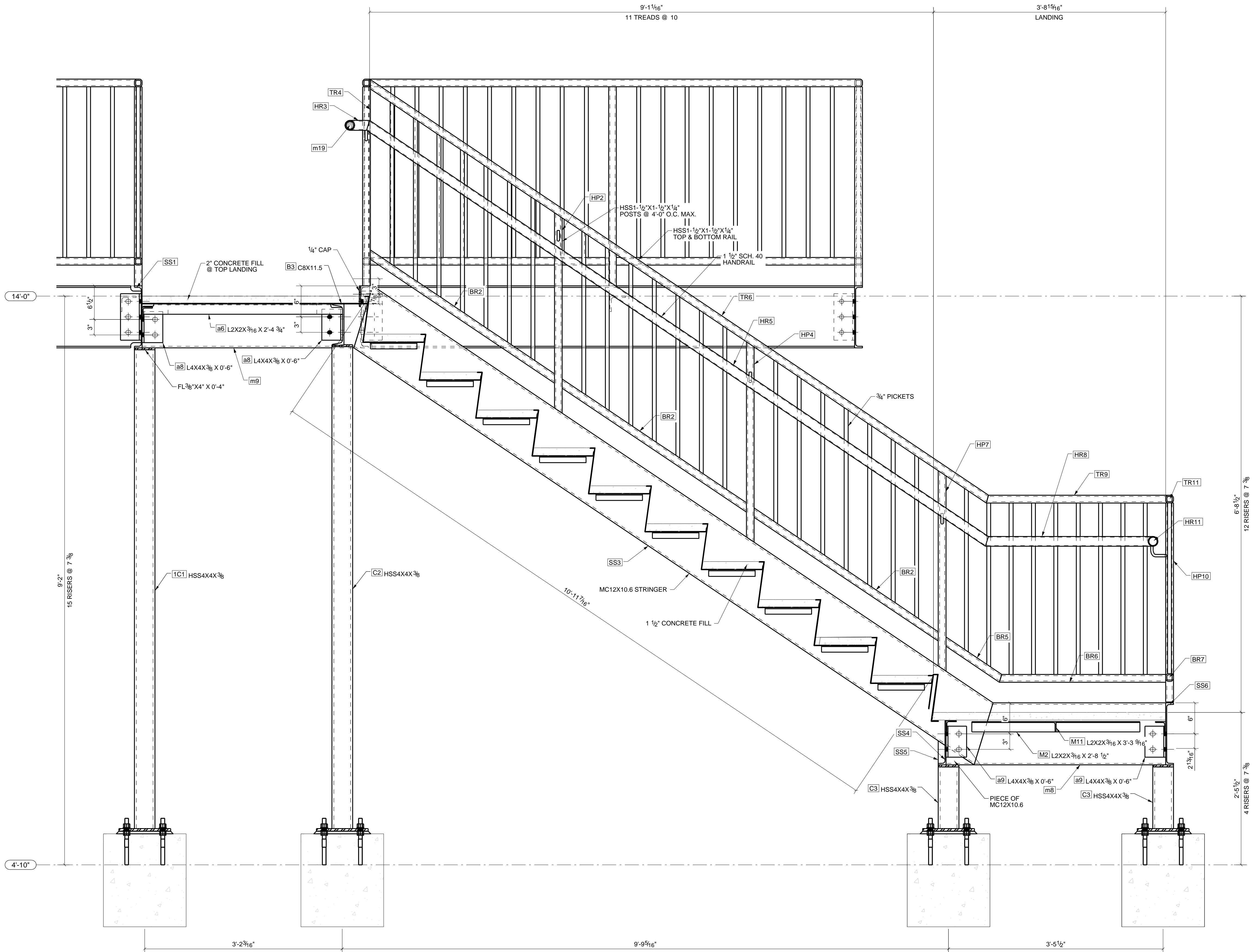

3-3
SCALE: 1/8" = 1'-0"

SEAL

ENGINEER

REV.	DATE	BY	DESCRIPTION
1	07/13/18	JS	ISSUED FOR APPROVAL

Project :		
Project No. :		
Status : Not Set	Comment:	
Detailer :	Holes:	Client:
DraftingServices.com	Weld: E70XXELECT	Drawing No.
Checker:	Grade:	M-03
	Coating:	Phase:
	Date: 07-13-2018	

Quantity Description Length

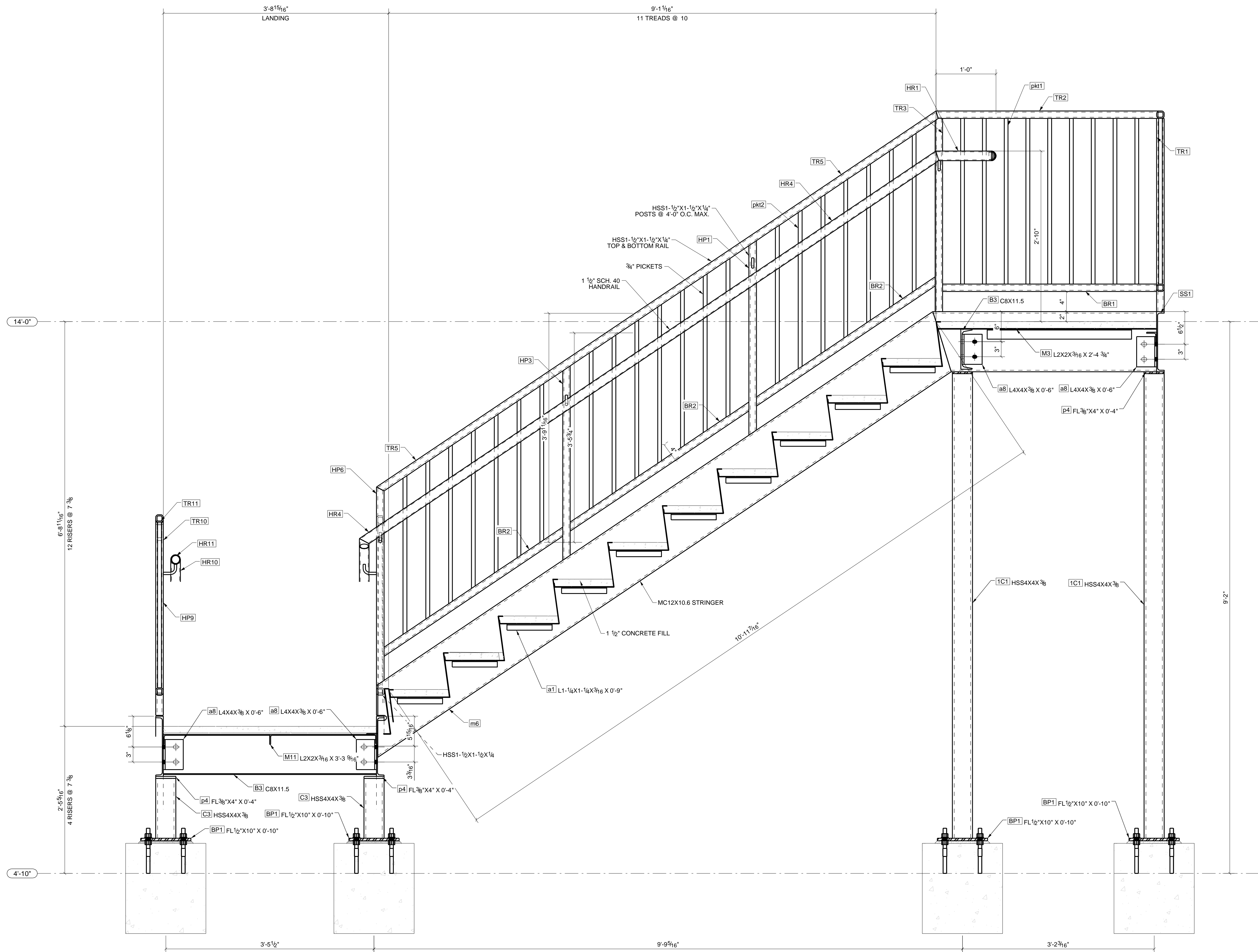

REV.	DATE	BY	DESCRIPTION
1	07/13/18	JS	ISSUED FOR APPROVAL

Project :		
Project No. :		
Status : Not Set	Comment:	
Detailer : DraftingServices.com	Holes:	Client:
Checker:	Weld: E70XXELECT	Drawing No. M-04
	Grade:	Phase:
	Coating:	Date: 07-13-2018
		A

SEAL

ENGINEER

Quantity Description Length

